Silicon NPN Phototransistor

Description

BPW13 is a high speed silicon NPN epitaxial planar phototransistor in a standard TO-18 hermetically sealed metal case.

Its flat glass window makes it ideal for applications with external optics. A base terminal is available to enable biasing and sensitivity control.

Features

- Hermetically sealed case
- Flat window
- Very wide viewing angle $\varphi = \pm 40^\circ$
- Exact central chip alignment
- Long range light barrier with an additional optics
- Base terminal available
- Fast response times
- Suitable for visible and near infrared radiation
- Selected into sensitivity groups

Applications

Detector in electronic control and drive circuits

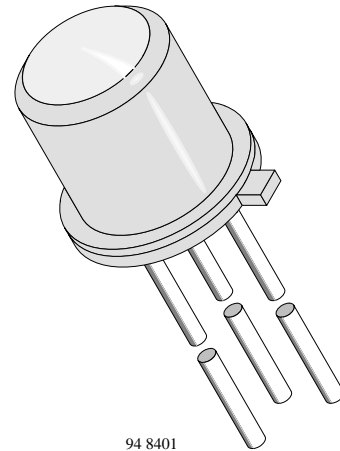

Absolute Maximum Ratings

 $T_{amb} = 25^{\circ}\text{C}$

Parameter	Test Conditions	Symbol	Value	Unit
Collector Base Voltage		V_{CBO}	32	V
Collector Emitter Voltage		V_{CEO}	32	V
Emitter Base Voltage		V_{EBO}	5	V
Collector Current		I_C	50	mA
Peak Collector Current	$t_p/T = 0.5, t_p \leq 10 \text{ ms}$	I_{CM}	100	mA
Total Power Dissipation	$T_{amb} \leq 25^{\circ}\text{C}$	P_{tot}	310	mW
Junction Temperature		T_j	150	$^{\circ}\text{C}$
Storage Temperature Range		T_{stg}	-55...+150	$^{\circ}\text{C}$
Soldering Temperature	$t \leq 5 \text{ s}$	T_{sd}	260	$^{\circ}\text{C}$
Thermal Resistance Junction/Ambient		R_{thJA}	400	K/W
Thermal Resistance Junction/Case		R_{thJC}	150	K/W

Basic Characteristics

 $T_{amb} = 25^{\circ}\text{C}$

Parameter	Test Conditions	Symbol	Min	Typ	Max	Unit
Collector Emitter Breakdown Voltage	$I_C = 1 \text{ mA}$	$V_{(BR)CEO}$	32			V
Collector Dark Current	$V_{CE} = 20 \text{ V}, E = 0$	I_{CEO}		1	100	nA
Collector Emitter Capacitance	$V_{CE} = 5 \text{ V}, f = 1 \text{ MHz}, E=0$	C_{CEO}		5.7		pF
Collector Base Capacitance	$V_{CB} = 5 \text{ V}, f = 1 \text{ MHz}, E=0$	C_{CBO}		6.5		pF
Angle of Half Sensitivity		φ		± 40		deg
Wavelength of Peak Sensitivity		λ_p		780		nm
Range of Spectral Bandwidth		$\lambda_{0.5}$		520...950		nm
Collector Emitter Saturation Voltage	$I_C = 0.1 \text{ mA}, I_B = 10 \mu\text{A}$	V_{CEsat}			0.3	V
Turn-On Time	$V_S=5\text{V}, I_C=5\text{mA}, R_L=100\Omega$	t_{on}		3.2		μs
Turn-Off Time	$V_S=5\text{V}, I_C=5\text{mA}, R_L=100\Omega$	t_{off}		2.7		μs
Cut-Off Frequency	$V_S=5\text{V}, I_C=5\text{mA}, R_L=100\Omega$	f_c		170		kHz

Type Dedicated Characteristics

 $T_{amb} = 25^{\circ}\text{C}$

Parameter	Type	Test Conditions	Symbol	Min	Typ	Max	Unit
Collector Light Current	BPW13A	$E_e=1\text{mW/cm}^2, \lambda=950\text{nm}, V_{CE}=5\text{V}$	I_{ca}	0.07	0.10	0.14	mA
	BPW13B	$E_e=1\text{mW/cm}^2, \lambda=950\text{nm}, V_{CE}=5\text{V}$	I_{ca}	0.10	0.15	0.20	mA
	BPW13C	$E_e=1\text{mW/cm}^2, \lambda=950\text{nm}, V_{CE}=5\text{V}$	I_{ca}	0.17	0.30		mA

Typical Characteristics ($T_{amb} = 25^{\circ}\text{C}$ unless otherwise specified)

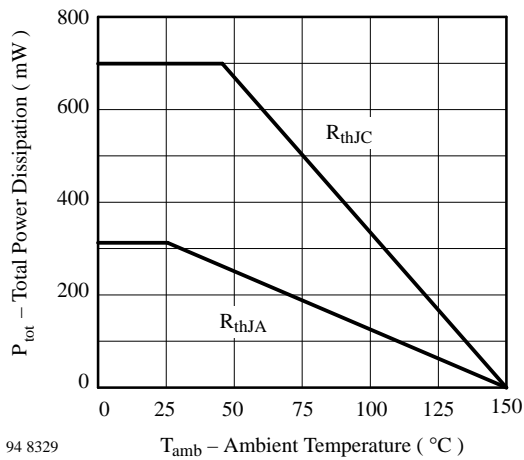

Figure 1 : Total Power Dissipation vs. Ambient Temperature

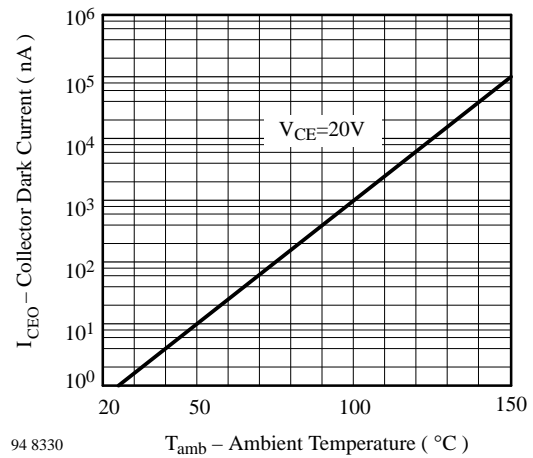

Figure 2 : Collector Dark Current vs. Ambient Temperature

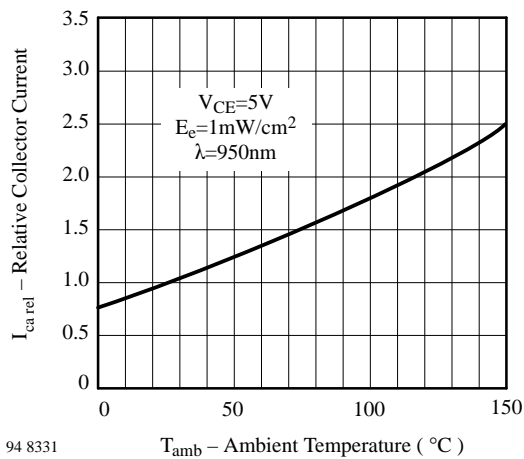

Figure 3 : Relative Collector Current vs. Ambient Temperature

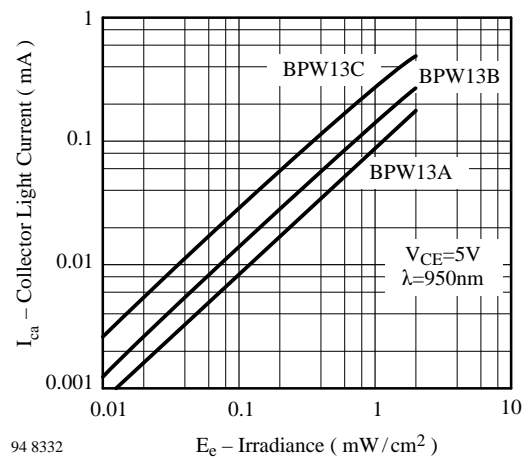

Figure 4 : Collector Light Current vs. Irradiance

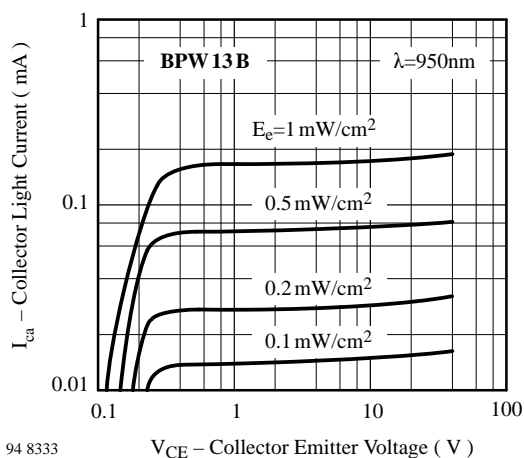

Figure 5 : Collector Light Current vs. Collector Emitter Voltage

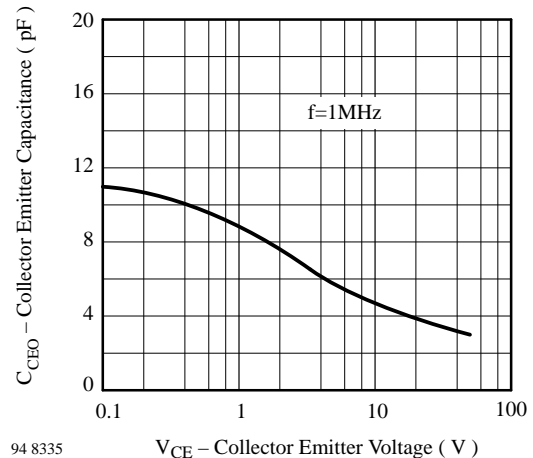
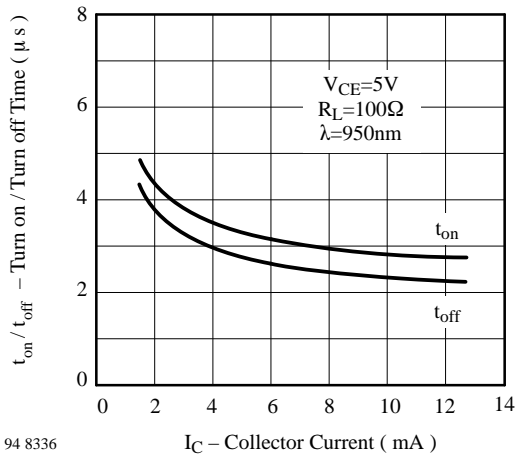

Figure 6 : Collector Emitter Capacitance vs. Collector Emitter Voltage



94 8336

I_C – Collector Current (mA)

Figure 7 : Turn On/Turn Off Time vs. Collector Current

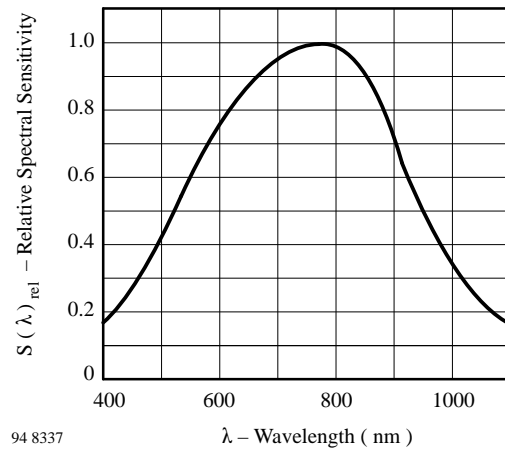

94 8337

λ – Wavelength (nm)

Figure 8 : Relative Spectral Sensitivity vs. Wavelength

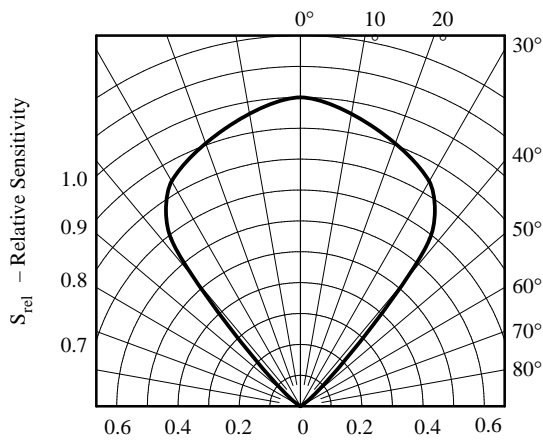

94 8338

Figure 9 : Relative Radiant Sensitivity vs. Angular Displacement

Dimensions in mm

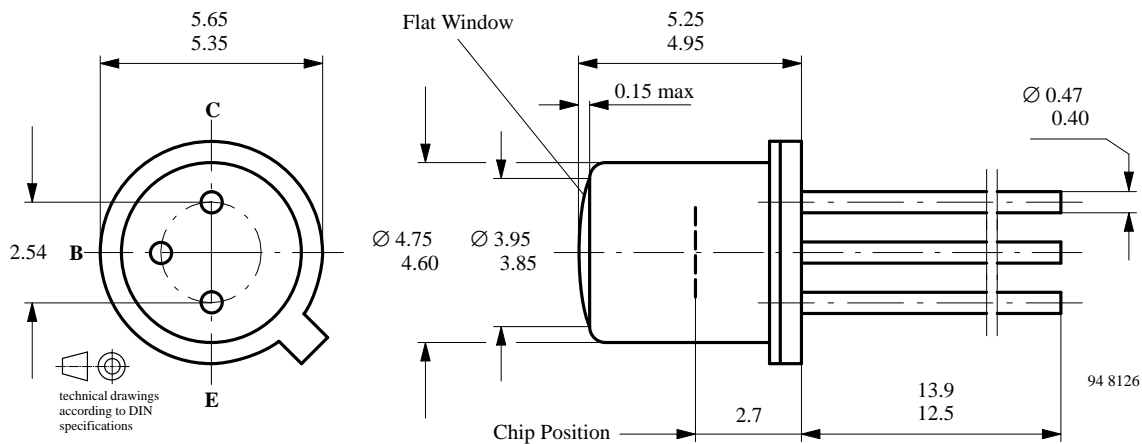

We reserve the right to make changes to improve technical design without further notice.

Parameters can vary in different applications. All operating parameters must be validated for each customer application by the customer. Should the buyer use TEMIC products for any unintended or unauthorized application, the buyer shall indemnify TEMIC against all claims, costs, damages, and expenses, arising out of, directly or indirectly, any claim of personal damage, injury or death associated with such unintended or unauthorized use.

TEMIC TELEFUNKEN microelectronic GmbH, P.O.B. 3535, D-74025 Heilbronn, Germany
Telephone: 49 (0)7131 67 2831, Fax Number: 49 (0)7131 67 2423